

DIN 7500 C

Thread rolling screws

Form C: button head according to DIN EN ISO 7045 | hexalobular drive

Steel | zinc-plated | Cr(VI)-free | Self-tapping thread

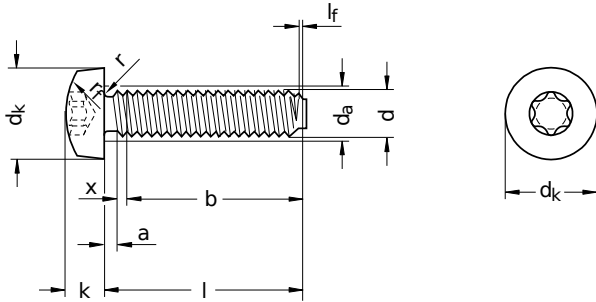

lf = Furchbereich

Diameter (d)	a max.	b min.	da max.	nominal size			nominal size			rf	r min.	Pitch (P)	x max.	Tool size
				5.0	6.0	8.0	2.1	2.4	3.1					
M2.5	0.9	25	3.1	5.0	4.70	5.0	2.1	1.96	2.1	4.0	0.10	0.45	1.10	T8
M3	1.0	25	3.6	5.6	5.30	5.6	2.4	2.26	2.4	5.0	0.10	0.50	1.25	T10
M4	1.4	38	4.7	8.0	7.64	8.0	3.1	2.92	3.1	6.5	0.20	0.70	1.75	T20
M5	1.6	38	5.7	9.5	9.14	9.5	3.7	3.52	3.7	8.0	0.20	0.80	2.00	T25
M6	2.0	38	6.8	12.0	11.57	12.0	4.6	4.30	4.6	10.0	0.25	1.00	2.50	T30

nominal size	Length (l)	
	min.	max.
5	4.76	5.24
6	5.76	6.24
8	7.71	8.29
10	9.71	10.29
12	11.65	12.35
14	13.65	14.35

nominal size	Length (l)	
	min.	max.
16	15.65	16.35
20	19.58	20.42
25	24.58	25.42
30	29.58	30.42
35	34.50	35.50
40	39.50	40.50

Diameter (d)	Length (l)											
	5	6	8	10	12	14	16	20	25	30	35	40
M2.5	●	●	●	●								
M3	●	●	●	●	●	●	●	●				
M4		●	●	●	●	●	●	●	●	●		●
M5			●	●	●	●	●	●	●	●		
M6			●	●		●	●	●	●	●		

• Combinations available in the eShop | Other sizes on request

All technical data refer to the measure mm

